

Saranan Asennus  
1400SL 1400SLM  
1400T 1600L

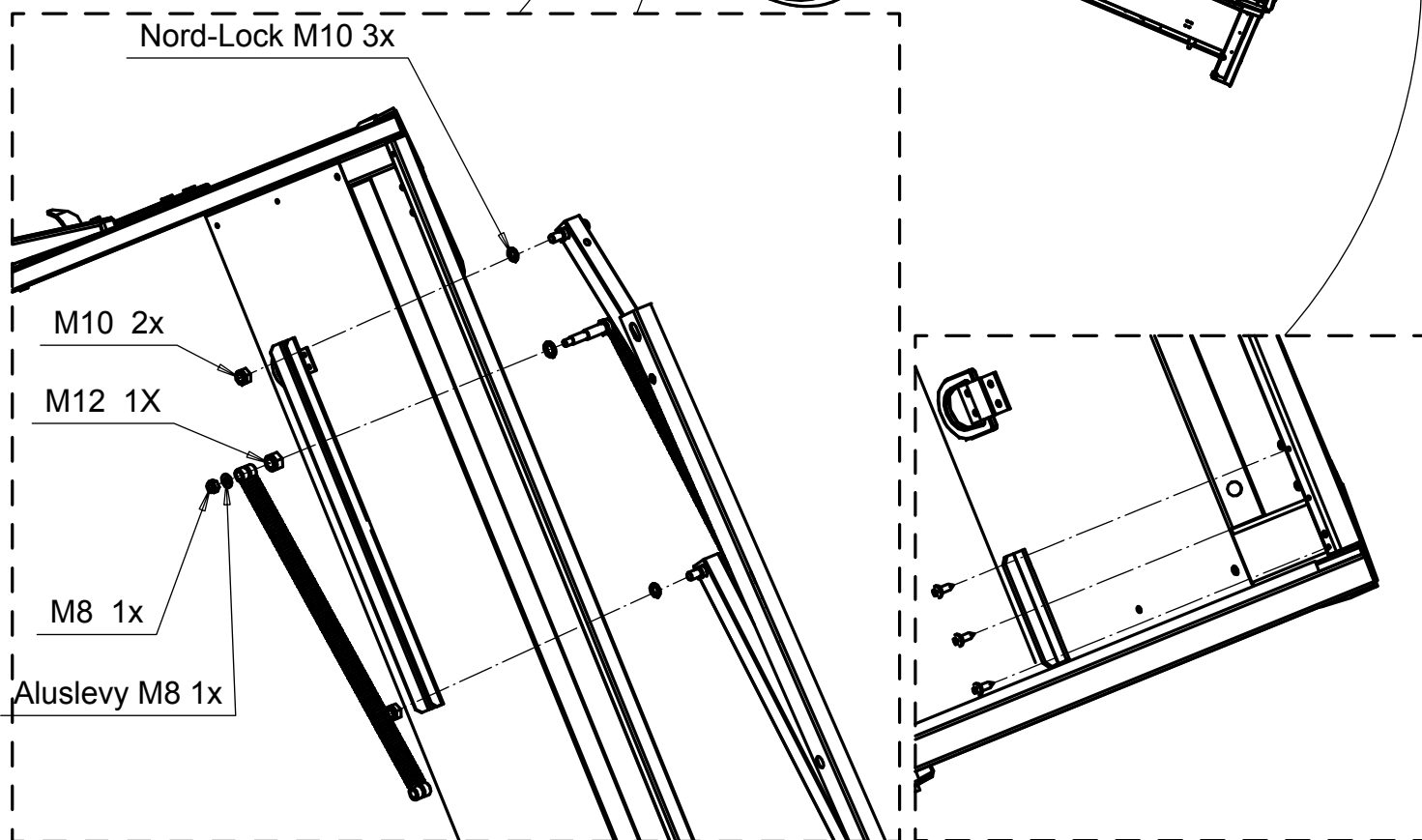
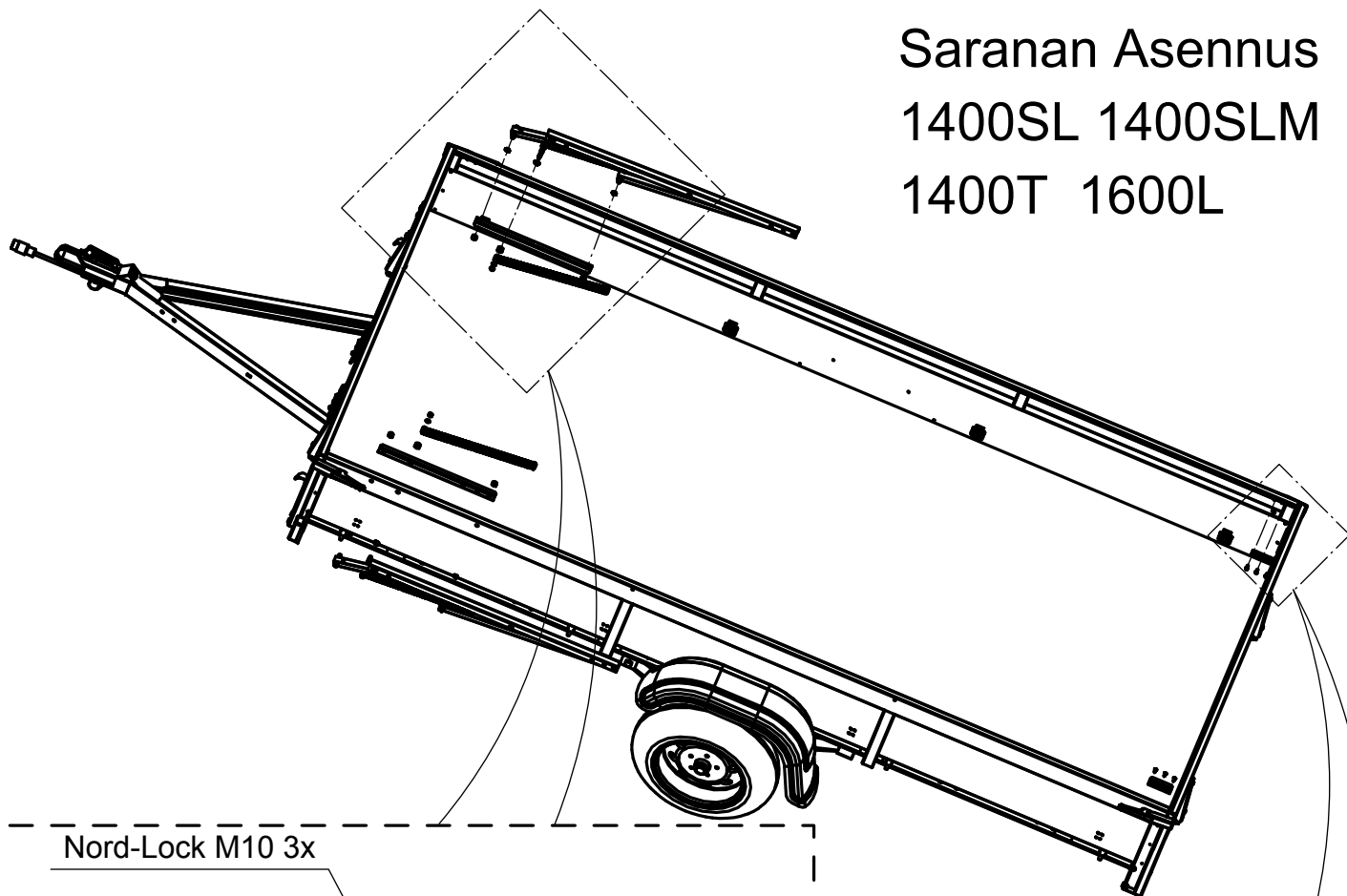

JUNCAR-KUOMUN  
ASENNUSOHJE  
MUULI 1400SL/SLM,  
1400T ja 1600L

- |                         |       |
|-------------------------|-------|
| 1. Kuomu                |       |
| 2. Lukko                | 1 kpl |
| 3. Avain                | 2 kpl |
| 4. M5x35/40mm           | 2 kpl |
| 5. Lukitustanko         | 1 kpl |
| 6. Pidätinruuvi M6x8mm  | 1 kpl |
| 7. Kannatin             | 2 kpl |
| 8. Mutteri IL M5        | 2 kpl |
| 9. Aluslevy M5          | 4 kpl |
| 10. Aluslaatta 5.3x15mm | 2 kpl |
| 11. Ruuvi M5x10mm       | 4 kpl |

1

VAIHE 2.  
KIINNITÄ SALPA

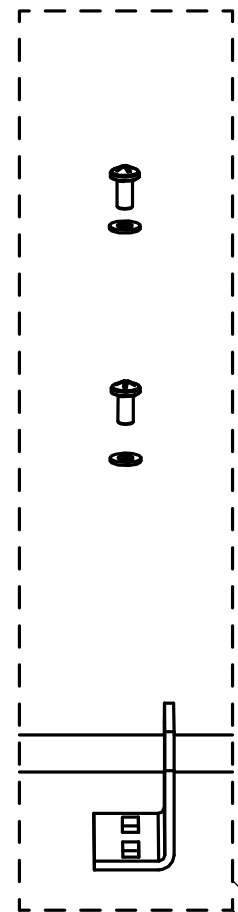
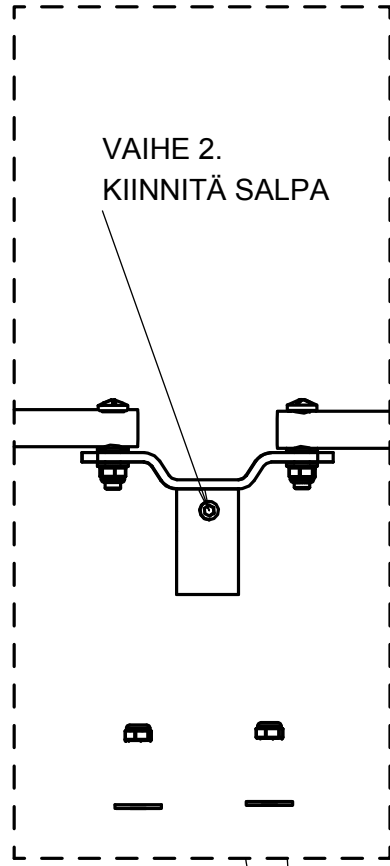

11  
9

11  
9

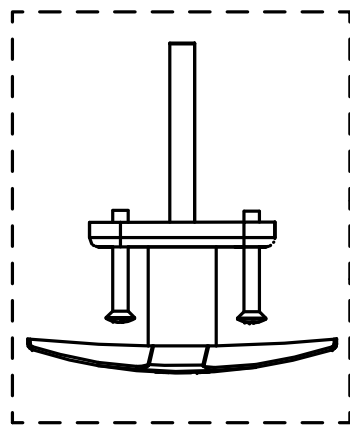

8  
10  
5  
6  
4  
3  
2

VAIHE 3.  
ESIKIRISTÄ  
KANNATTIMET

VAIHE 1.  
KIINNITÄ LUKKO

